

TOTAL UNIT BREAKDOWN TABLE					
FLOOR	STUDIO	1 BR	2 BR	3 BR	TOTAL
1	1	3	6	1	11
2	2	4	6	-	12
3	1	1	4	-	6
4	1	1	4	-	6
TOTAL	5	9	20	1	35

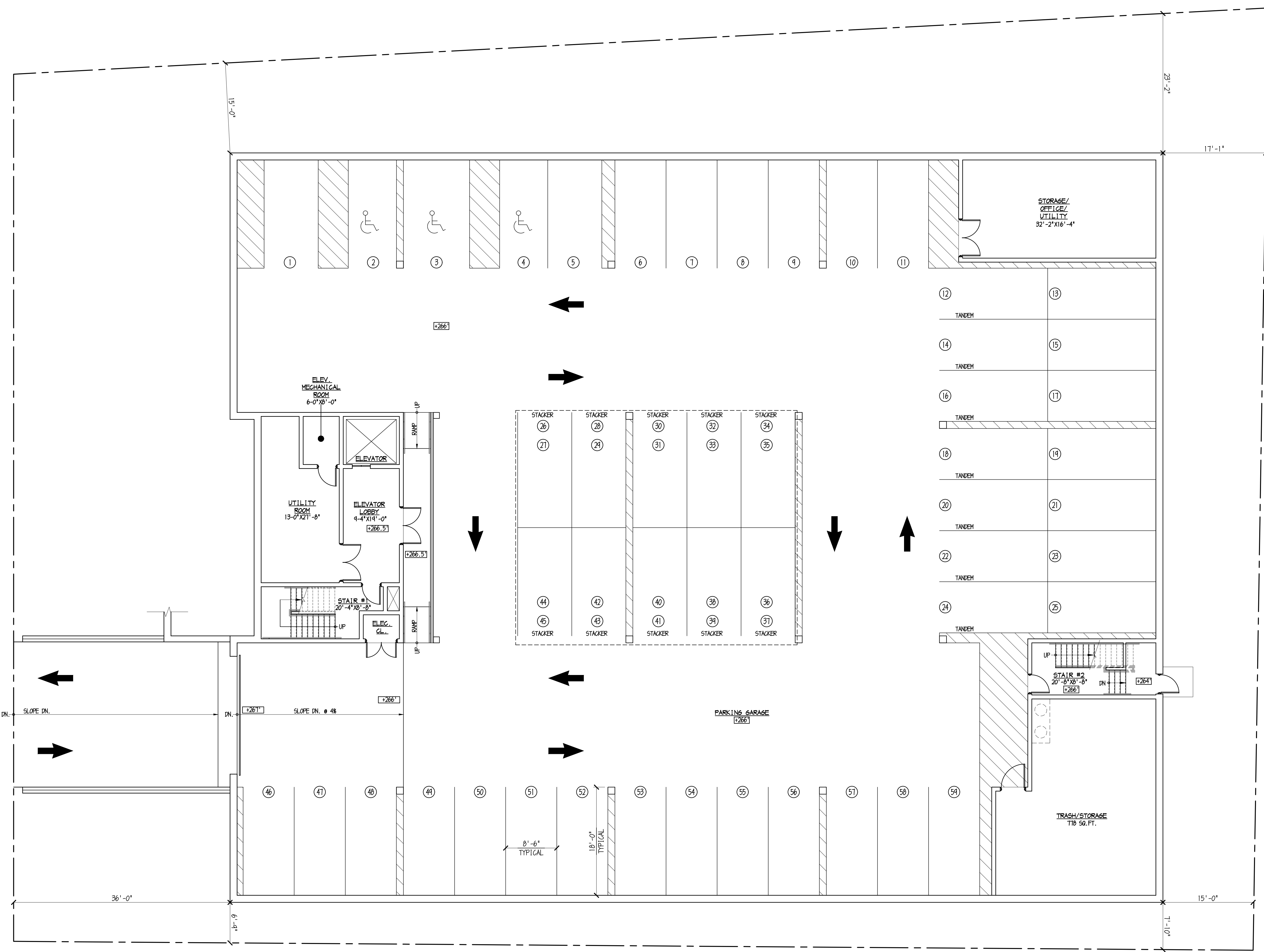

PARKING LEVEL GROSS FLOOR AREA: 14,200 SQ. FT.

A PARKING LOWER LEVEL PLAN
 SCALE: 1/8" = 1'-0"
 NORTH

(54) TOTAL PARKING SPACES PROVIDED.
 INCLUDING (3) H.C. ACCESSIBLE SPACES (REQ'D)
 (14) TANDEM SPACES, AND (20) STACKER SPACES.
 TYPICAL PARKING SPACE IS 8'-6" X 10'-0" DEEP,
 TYPICAL DRIVE AISLE IS 24'-0" WIDE. (66)
 PARKING SPACES REQUIRED.

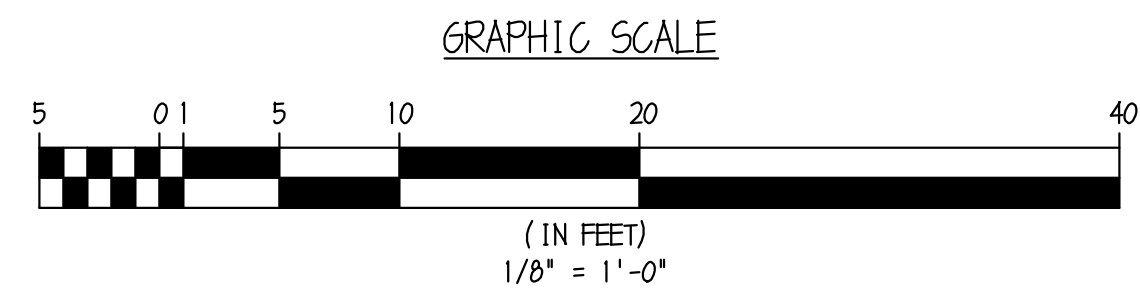

11 MARCH 2021 FOR MUNICIPAL RESUBMISSION
 ISSUES & REVISIONS

PROPOSED RESIDENTIAL DEVELOPMENT FOR:
21-25 GROVE ASSOCIATES LLC
 TAX MAP: BLOCK - 1702, LOT - 22
 21-25 GROVE AVENUE
 VERONA, NEW JERSEY

BILOW GARRETT GROUP
 ARCHITECTS AND PLANNERS, PC
 161 MAIN ST. • RIDGEFIELD PARK, NJ 07660
 (201) 807-0407 • FAX (201) 807-0513
 DAVID N. BILOW NJ AI 5899 NY 10029
 ANTHONY GARRETT NJ AI 5498 NY 22174

PARKING LOWER LEVEL PLAN
 DRAWING NUMBER **A-100**

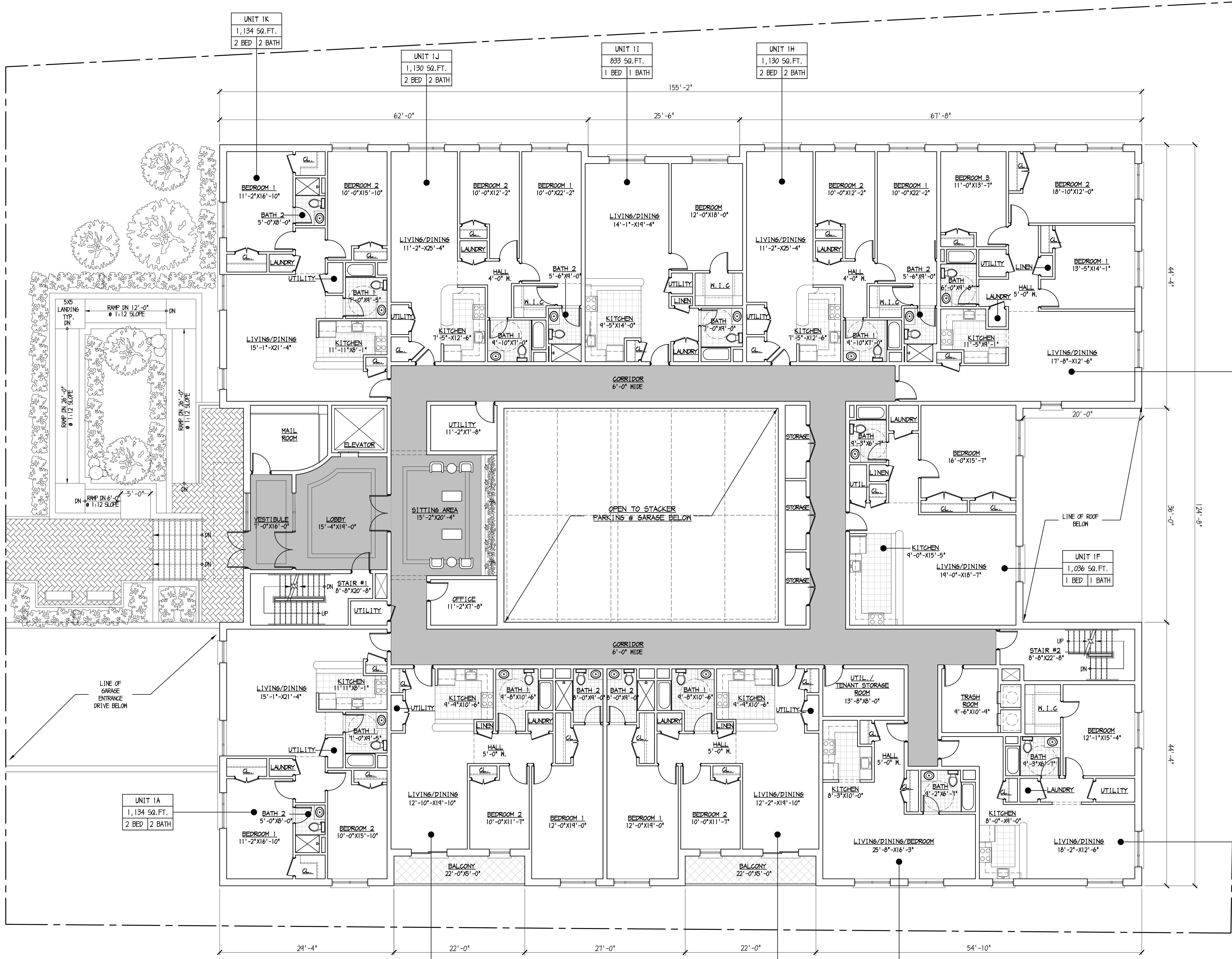

FIRST FLOOR UNIT BREAKDOWN:	
STUDIO UNIT	1
ONE (1) BEDROOM/ 1 BATH UNITS:	3
TWO (2) BEDROOM/ 2 BATH UNITS:	6
THREE (3) BEDROOM/ 1 BATH UNITS:	1
TOTAL NUMBER OF UNITS:	11

FIRST FLOOR GROSS FLOOR AREA: 16,546 SQ. FT.

UNIT 16
1,414 SQ. FT.
3 BED 1 BATH

UNIT 1F
1,036 SQ. FT.
1 BED 1 BATH

UNIT 1E
819 SQ. FT.
1 BED 1 BATH

UNIT 1A
1,134 SQ. FT.
2 BED 2 BATH

UNIT 1B
1,122 SQ. FT.
2 BED 2 BATH

UNIT 1G
1,122 SQ. FT.
2 BED 2 BATH

UNIT 1D
583 SQ. FT.
STUDIO 1 BATH

UNIT 1I
833 SQ. FT.
1 BED 1 BATH

UNIT 1H
1,130 SQ. FT.
2 BED 2 BATH

UNIT 1J
1,130 SQ. FT.
2 BED 2 BATH

UNIT 1K
1,134 SQ. FT.
2 BED 2 BATH

11 MARCH 2021 FOR MUNICIPAL RESUBMISSION
ISSUES & REVISIONS

PROPOSED RESIDENTIAL DEVELOPMENT FOR:
21-25 GROVE ASSOCIATES LLC
TAX MAP: BLOCK - 1702, LOT - 22
21-25 GROVE AVENUE
VERONA, NEW JERSEY

BILOW GARRETT GROUP
ARCHITECTS AND PLANNERS, PC
161 MAIN ST. • RIDGEFIELD PARK, NJ 07660
(201) 807-0407 • FAX (201) 807-0513
DAVID N. BILOW NJ AI 5899 NY 10029
ANTHONY GARRETT NJ AI 5498 NY 2274

FIRST FLOOR PLAN DRAWING NUMBER
A-101

A FIRST FLOOR PLAN
SCALE: 1/8" = 1'-0"
NORTH

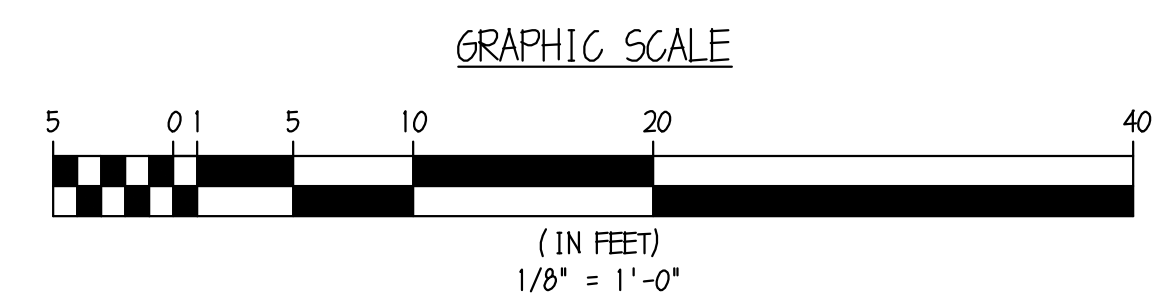

JOB NUMBER: 90202 PATH-DWGS/2-DWG/ISSUES REVISIONS SHEET: 20/20 DWG: 21-25 GROVE ASSOCIATES LLC

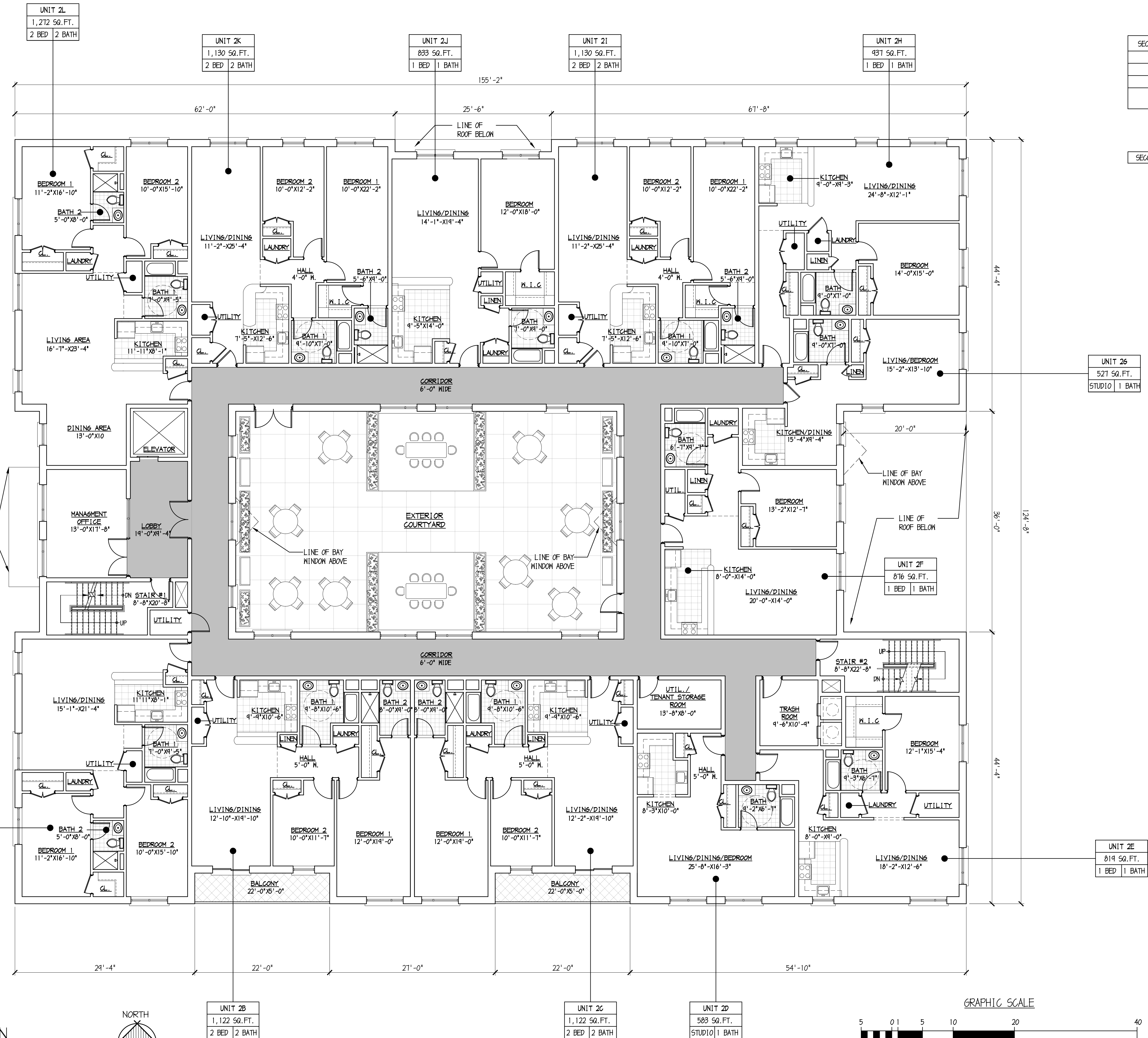

SECOND FLOOR UNIT BREAKDOWN:	
STUDIO UNIT	2
ONE (1) BEDROOM / 1 BATH UNITS:	4
TWO (2) BEDROOM / 2 BATH UNITS:	6
TOTAL NUMBER OF UNITS:	12

SECOND FLOOR GROSS FLOOR AREA: 15,186 SQ. FT.

UNIT 26
521 SQ. FT.
STUDIO | 1 BATH

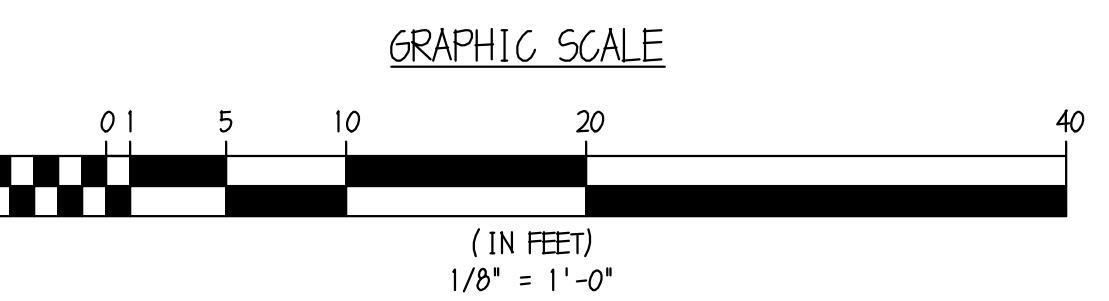

A SECOND FLOOR PLAN
SCALE: 1/8"=1'-0"

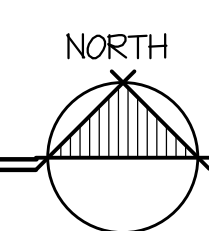

11 MARCH 2021 FOR MUNICIPAL RESUBMISSION
ISSUES & REVISIONS

PROPOSED RESIDENTIAL DEVELOPMENT FOR:
21-25 GROVE ASSOCIATES LLC
TAX MAP: BLOCK - 1702, LOT - 22

21-25 GROVE AVENUE
VERONA, NEW JERSEY

BILOW GARRETT GROUP
ARCHITECTS AND PLANNERS, PC
161 MAIN ST. • RIDGEFIELD PARK, NJ 07660
(201) 807-0407 • FAX (201) 807-0513

DAVID N. BILOW NJ AI 5899 NY 10029
ANTHONY GARRETT NJ AI 5498 NY 2274

SECOND FLOOR PLAN DRAWING NUMBER
A-102

THIRD FLOOR UNIT BREAKDOWN:	
STUDIO UNIT	1
ONE (1) BEDROOM/ 1 BATH UNITS:	1
TWO (2) BEDROOM/ 2 BATH UNITS:	4
TOTAL NUMBER OF UNITS:	6

THIRD FLOOR GROSS FLOOR AREA: 9,261 SQ. FT.

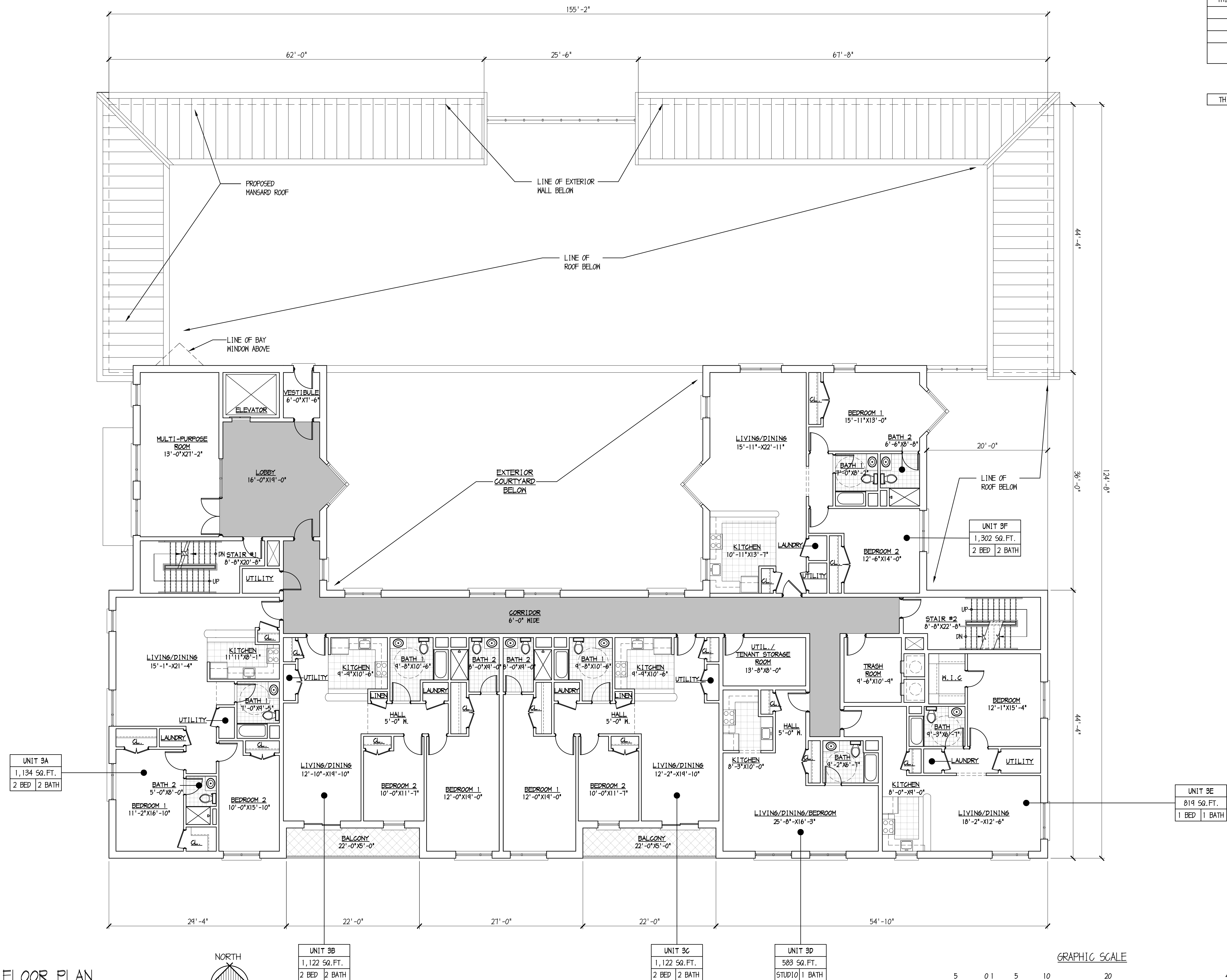

A THIRD FLOOR PLAN
SCALE: 1/8" = 1'-0"

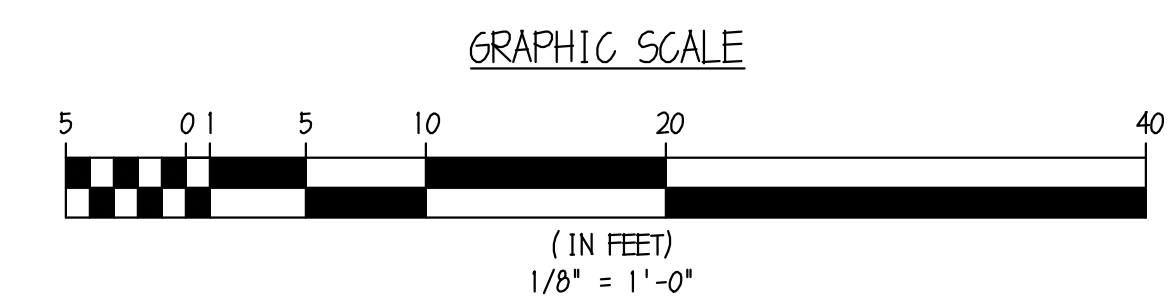
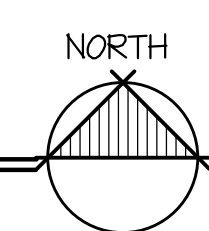

11 MARCH 2021 FOR MUNICIPAL RESUBMISSION
ISSUES & REVISIONS

PROPOSED RESIDENTIAL DEVELOPMENT FOR:
21-25 GROVE ASSOCIATES LLC
TAX MAP: BLOCK - 1702, LOT - 22

21-25 GROVE AVENUE
VERONA, NEW JERSEY

BILOW GARRETT GROUP
ARCHITECTS AND PLANNERS, PC
161 MAIN ST. • RIDGEFIELD PARK, NJ 07660
(201) 807-0407 • FAX (201) 807-0513
DAVID N. BILOW NJ AI 5499 NY 10029
ANTHONY GARRETT NJ AI 5498 NY 22174

THIRD FLOOR PLAN
DRAWING NUMBER
A-103

FOURTH FLOOR UNIT BREAKDOWN:	
STUDIO UNIT	1
ONE (1) BEDROOM/ 1 BATH UNITS:	1
TWO (2) BEDROOM/ 2 BATH UNITS:	4
TOTAL NUMBER OF UNITS:	6

FOURTH FLOOR GROSS FLOOR AREA: 9,282 SQ. FT.

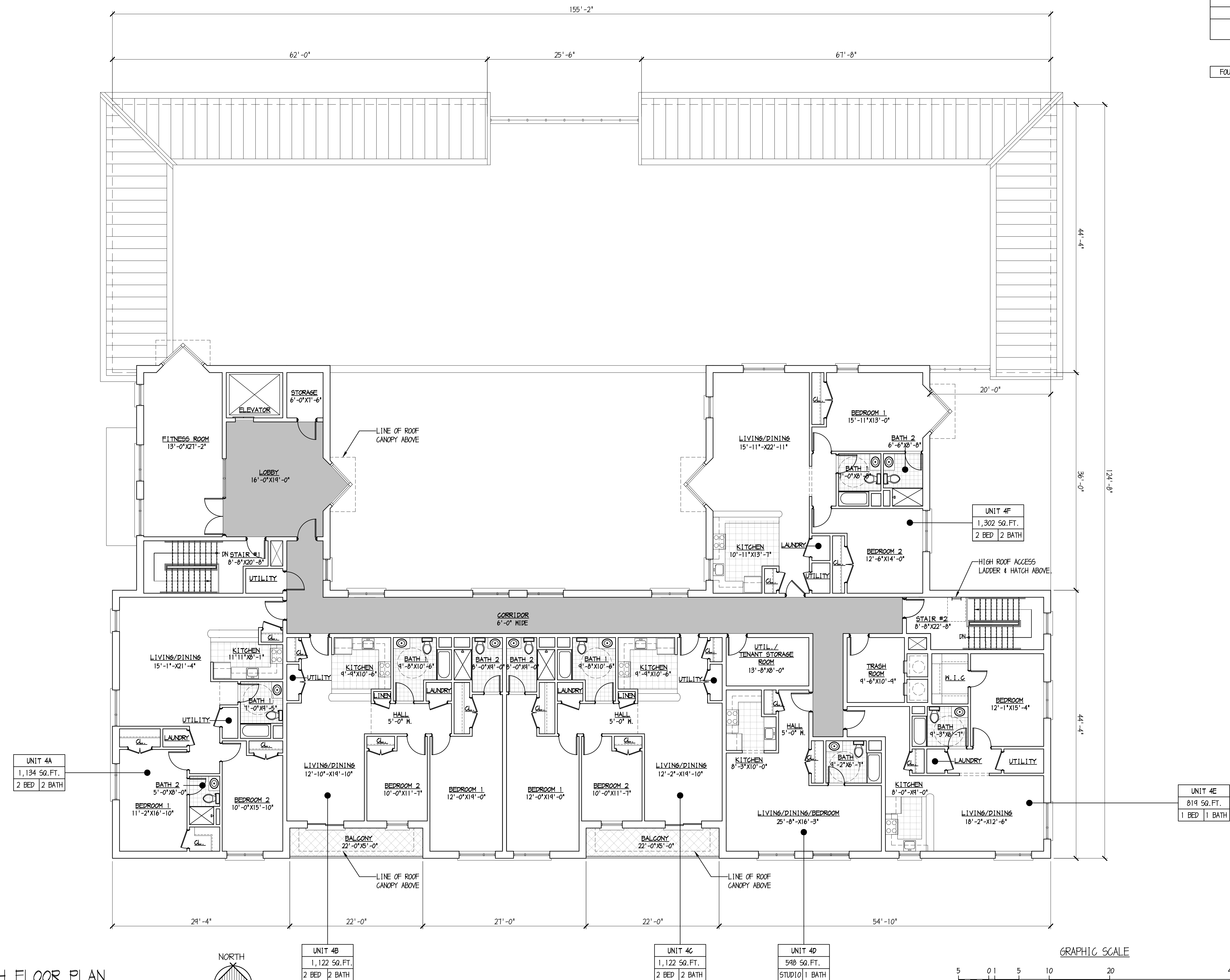

A FOURTH FLOOR PLAN
SCALE: 1/8" = 1'-0"

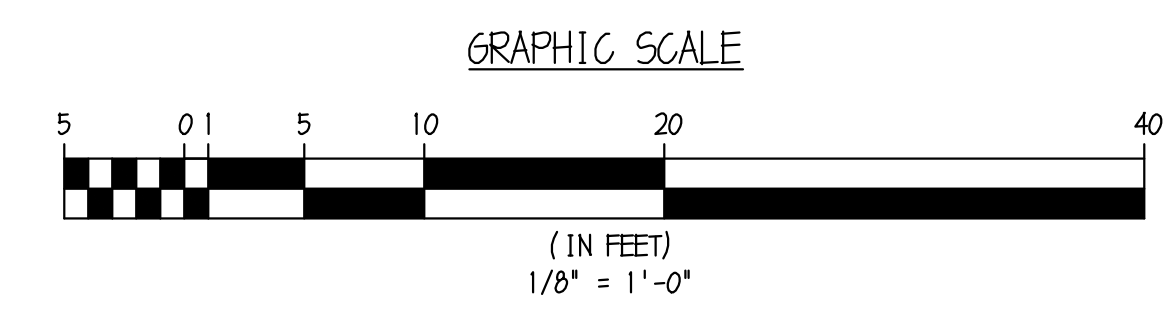
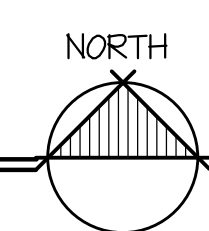

11 MARCH 2021 FOR MUNICIPAL RESUBMISSION
ISSUES & REVISIONS

PROPOSED RESIDENTIAL DEVELOPMENT FOR:
21-25 GROVE ASSOCIATES LLC
TAX MAP: BLOCK - 1702, LOT - 22

21-25 GROVE AVENUE
VERONA, NEW JERSEY

BILOW GARRETT GROUP
ARCHITECTS AND PLANNERS, PC
161 MAIN ST. • RIDGEFIELD PARK, NJ 07660
(201) 807-0407 • FAX (201) 807-0513
DAVID N. BILOW NJ AI 5899 NY 10029
ANTHONY GARRETT NJ AI 5498 NY 22174

FOURTH FLOOR PLAN
DRAWING NUMBER
A-104

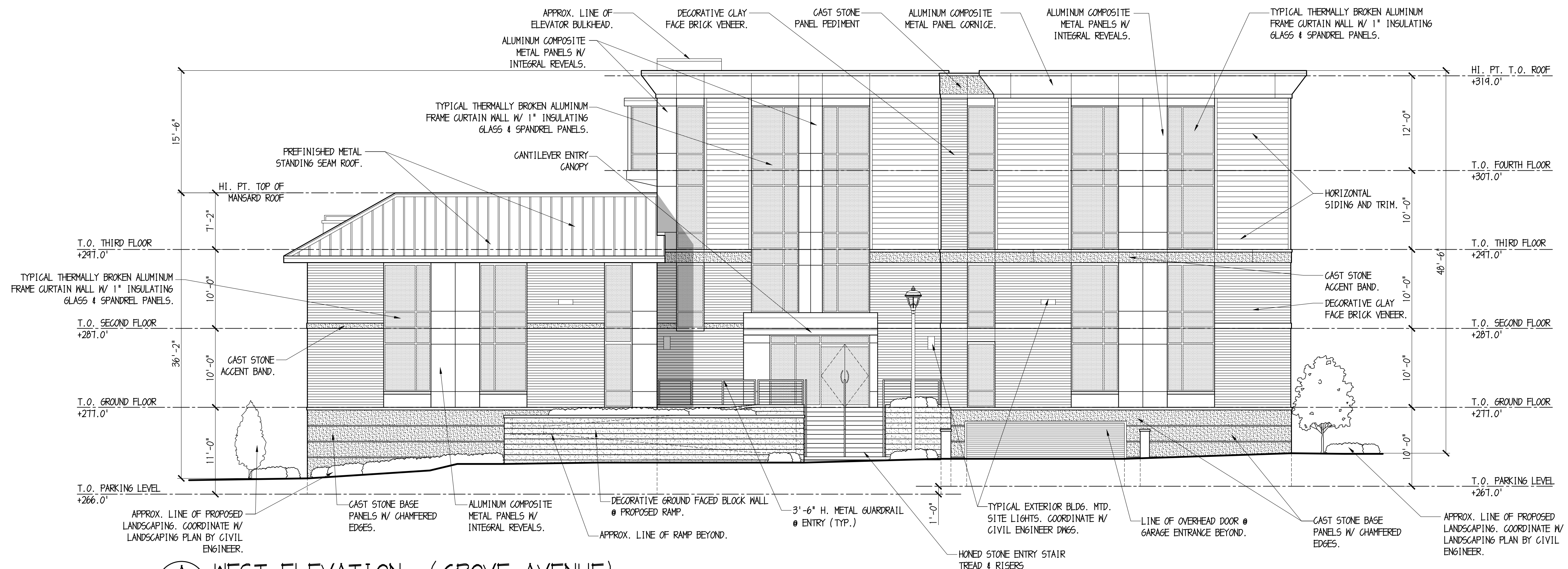

A WEST ELEVATION (GROVE AVENUE)
 A-200 SCALE: 1/8"=1'-0"

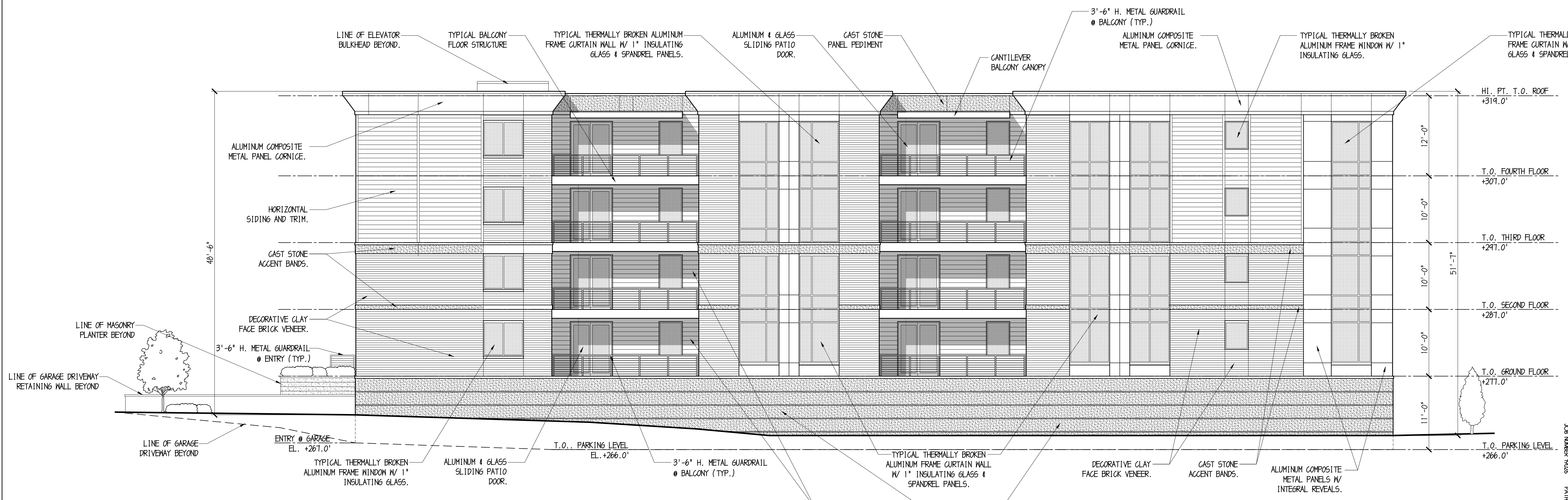

B SOUTH ELEVATION
 A-200 SCALE: 1/8"=1'-0"

11 MARCH 2021 FOR MUNICIPAL RESUBMISSION
 ISSUES & REVISIONS

PROPOSED RESIDENTIAL DEVELOPMENT FOR:
21-25 GROVE ASSOCIATES LLC
 TAX MAP: BLOCK - 1702, LOT - 22

21-25 GROVE AVENUE
 VERONA, NEW JERSEY

BILLOW GARRETT GROUP
 ARCHITECTS AND PLANNERS, PC
 161 MAIN ST. • RIDGEFIELD PARK, NJ 07660
 (201) 807-0407 • FAX (201) 807-0513

DAVID N. BILLOW NJ AI 5899 NY 10029
 ANTHONY GARRETT NJ AI 5498 NY 22174

WEST AND SOUTH ELEVATIONS DRAWING NUMBER
A-200

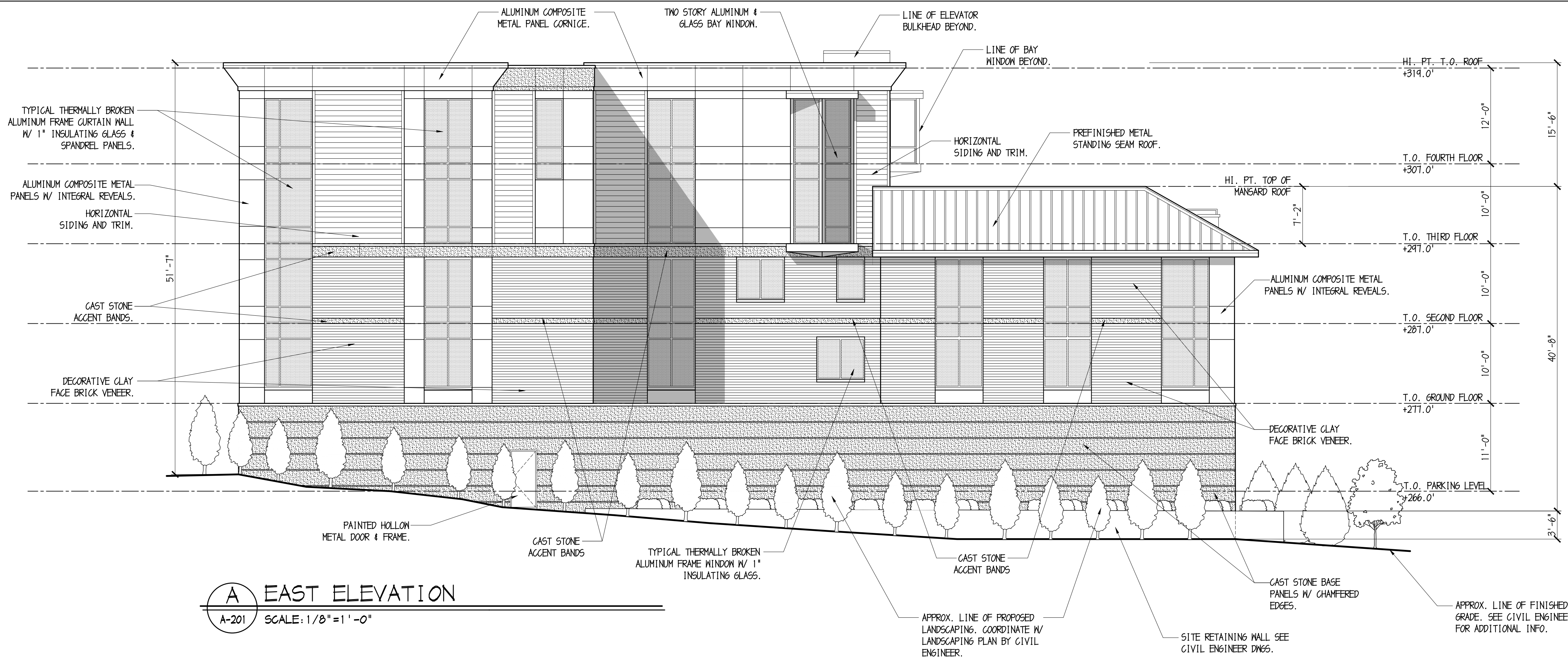

A EAST ELEVATION
 A-201 SCALE: 1/8" = 1'-0"

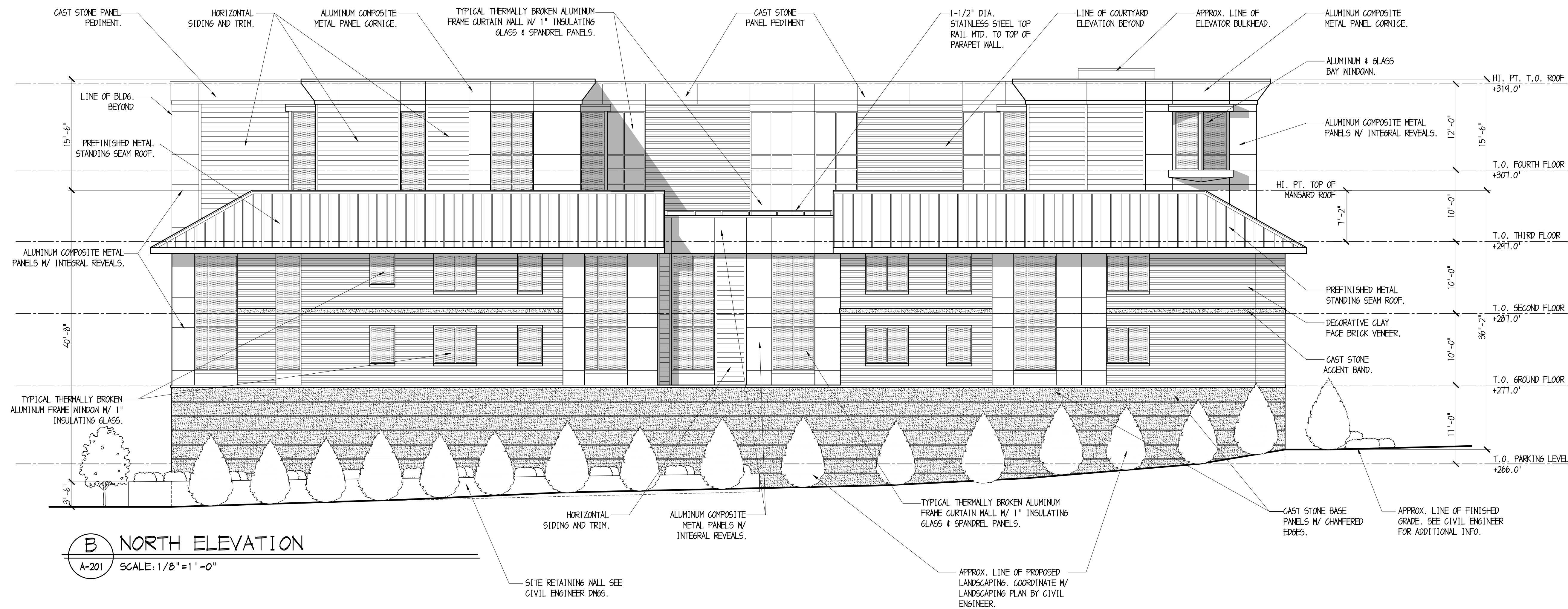

B NORTH ELEVATION
 A-201 SCALE: 1/8" = 1'-0"

11 MARCH 2021 FOR MUNICIPAL RESUBMISSION
 ISSUES & REVISIONS

PROPOSED RESIDENTIAL DEVELOPMENT FOR:
21-25 GROVE ASSOCIATES LLC
 TAX MAP: BLOCK - 1702, LOT - 22

21-25 GROVE AVENUE
 VERONA, NEW JERSEY

BILOW GARRETT GROUP
 ARCHITECTS AND PLANNERS, PC
 161 MAIN ST. • RIDGEFIELD PARK, NJ 07660
 (201) 807-0407 • FAX (201) 807-0513

DAVID N. BILOW NY 10029
 ANTHONY GARRETT NJ 14398 NY 22174

EAST AND NORTH ELEVATIONS DRAWING NUMBER
A-201

JOB NUMBER 90201 EAST-GROVE/21-25 GROVE ASSOCIATES LLC/VERONA, NJ/2021/03/11